

# Fluido®

Blood and Fluid Warming



## The Next Generation Blood and Fluid Warming Systems

**TSC** The Surgical  
Company

PTM

Specialization through Innovation

# UNINTENDED HYPOTHERMIA

One of the contributing factors of unintended hypothermia is the intravenous (IV) delivery of cold blood and fluids, resulting in a reduction of the main body temperature by 0.25°C for every litre of IV crystalloid solution administered at room temp (21°C) or with 500 cc of blood at 5°C.<sup>1,2,3</sup>

Blood and Fluid Warming can help to maintain normothermia and will contribute to a positive patient outcome by consistently providing normothermic blood and fluids at all flow rates. Maintaining the right patient body temperature results in clinical and economic benefits by reducing the length of

hospital stay and complications.<sup>4,5,6</sup> The Surgical Company PTM has developed a complete range of blood and fluid warming systems equipped with safe and controlled technology to deliver consistently warm blood and IV fluids to patients undergoing surgical procedures, from low to high flow rates.

## HIGH FLOW

Fluido® AirGuard System is a Blood and Fluid Warming system designed to rapidly warm to normothermic temperature. The system is suitable for all applications and all common flow rates, from moderate to high flow rates<sup>8</sup>.

## Fluido® AirGuard System

Blood and Fluid Warming

Fluido® AirGuard System comprises:

- Fluido® Blood and Fluid Warmer
- Fluido® Air Guard
- Fluido® Pressure Chambers
- Fluido® Compressor
- Fluido® IV-Pole

### Fluido® Pressure Chambers

500ml and 1000ml bags

Pressure Regulator (0-300mmHg)

### Fluido® Air Guard

Cardiac Floating

Air Detection

Automatic Shut off Clamp

### Fluido® Blood and Fluid Warmer

Cardiac Floating

Adjustable Temperature Setpoint 30 - 39°C

Flow & Volume Indicator

### Fluido® IV-Pole

Integrated Air Tubing

Latex Free, Anti-Static Castors with Brakes

Stable Design

### Fluido® Compressor

Cardiac Floating

Powerful



- 1 Plug-in
- 2 Prepare
- 3 Power On

# FLUIDO® AIRGUARD SYSTEM



## Fluido® Blood and Fluid Warmer | Article number 651230 - 651115

|                                       |                           |             |
|---------------------------------------|---------------------------|-------------|
| Voltage                               | 220 - 240V~               | 110 - 120V~ |
| Current                               | 6A                        | 12A         |
| Frequency                             | 50/60Hz                   |             |
| Max. power                            | 1400VA                    |             |
| Dimensions                            | 435 x 250 x 315mm         |             |
| Weight                                | 9.5kg                     |             |
| Temperature setpoint                  | 30 - 39°C                 |             |
| Unit of temperature setpoint increase | 1°C                       |             |
| Classification (IEC 60601-1)          | Class I, Cardiac Floating |             |
| Classification (IEC 60529)            | IPX1                      |             |



## Fluido® Air Guard | Article number 660400 - 661400

|                              |                           |             |
|------------------------------|---------------------------|-------------|
| Voltage                      | 220 - 240V~               | 110 - 120V~ |
| Current                      | 0.2A                      | 0.3A        |
| Frequency                    | 50/60Hz                   |             |
| Max. power                   | 25VA                      |             |
| Dimensions                   | 310 x 150 x 190mm         |             |
| Weight                       | 4.5kg                     |             |
| Classification (IEC 60601-1) | Class I, Cardiac Floating |             |
| Classification (IEC 60529)   | IPX1                      |             |



## Fluido® Pressure Chambers | Article number 660300

|                                    |                   |
|------------------------------------|-------------------|
| Max. overpressure                  | 300mmHg ± 10%     |
| Dimensions                         | 370 x 400 x 150mm |
| Weight                             | 4.2kg             |
| Classification (MDR (EU) 2017/745) | Class IIa         |



## Fluido® Compressor | Article number 660200A

|                              |                           |
|------------------------------|---------------------------|
| Voltage                      | 100 - 240V~               |
| Current                      | 0.08 - 0.03A              |
| Frequency                    | 50/60Hz                   |
| Max. power                   | 6 - 16VA                  |
| Air flow                     | 3l/min (unloaded)         |
| Max. pressure                | 1.0bar/750mmHg            |
| Dimensions                   | 210 x 150 x 150mm         |
| Weight                       | 1.3kg                     |
| Classification (IEC 60601-1) | Class I, Cardiac Floating |
| Classification (IEC 60529)   | IPX1                      |

## Fluido® IV-Pole | Article number 660500-B

|                   |                                       |
|-------------------|---------------------------------------|
| Adjustable height | 1920 - 2230mm ±10mm                   |
| Dimensions Pole   | ø 38mm                                |
| Dimensions Base   | ø 740mm                               |
| Weight            | 13kg                                  |
| Castors           | 5, anti-static, latex free, 5 brakes! |



Watch the Fluido® AirGuard System video

 SAFETY

 SPEED

 CONTROL

When administrating IV fluids under pressure, it is necessary to use a reliable safety mechanism to avoid the risk for air embolism to the patient.

The Fluido® AirGuard System is provided with an ultra-sonic sensor to automatically shut off the IV-line in case air is detected in the bubble trap.

The Fluido® Blood and Fluid Warmer is warming blood and fluids with infrared technology. It is a dry method, preventing risks of waterborne contamination. The Fluido® disposable sets move easily with the patient between the per- and postoperative phases. This allows the caregiver to carry on fluid administration while conveying the patient through different wards with one single disposable and reducing the risk of infection and eliminating additional cost.

Based on in line sensors, the Fluido® Blood and Fluid Warmer calculates the required energy to safely warm the perfusates. Algorithms compensate for the heat loss in the patient line to ensure accurate heat adjustment.

## FLUIDO® DISPOSABLE SETS

### Fluido® Standard Set | Article number 671200

Ⓞ Manual air relief

Ⓞ Patient line (1500mm)

Max. flow: 400ml/min<sup>9</sup>

Priming volume: 90ml

Backflow valve

### Fluido® Trauma Set | Article number 671500

Ⓞ Manual air relief

Ⓞ Patient line (1500mm)

Ⓞ Administration port

Max. flow: 800ml/min<sup>9</sup>

Filter: ISO 1135-5 Compliant

Priming volume: 145ml

Backflow valve

### Fluido® Trauma Plus Set | Article number 671700

Ⓞ Manual air relief

Ⓞ Patient line (2000mm)

Ⓞ Administration port

Max. flow: 900ml/min<sup>9</sup>

Filter: ISO 1135-5 Compliant

Priming volume: 155ml

Backflow valve

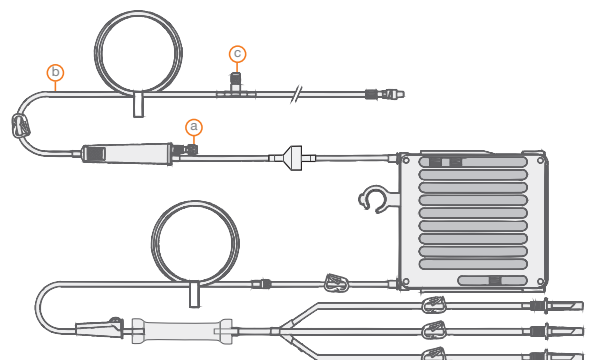
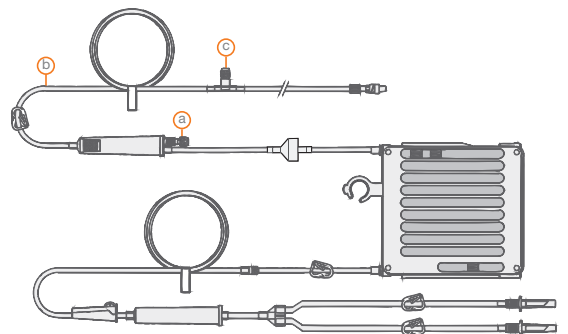
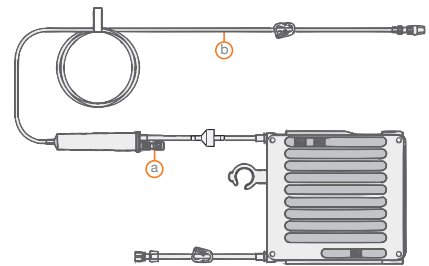

Fluido® sets do not contain natural latex components.

# LOW/MODERATE FLOW

## Fluido® Compact Blood and Fluid Warming

Fluido® Compact is a low to moderate flow Blood and Fluid Warming system for daily use. Easy to use, safe and cost effective with an outstanding performance.

Fluido® Compact combines ease of use with low operational costs. The intuitive control panel is operated with only a single button. The disposable sets come in two configurations. A standard set consisting of a cassette with a 400mm long patient line and an extended set with a 700mm long patient line, a drip chamber and an access point. Fluido® Compact is an **easy-to-use** system to help prevent

inadvertent perioperative hypothermia to improve patient's outcome. The different components of the system have a durable and long-lasting design and are maintenance free. Correct operation of the device for safety and performance only needs to be checked once a year.

The disposable sets **move easily with the patient between different systems.** This

allows the caregiver to warm IV fluids for the patient across departments with only one disposable set and without having to move the warming unit.

The independent safety controller **ensures patient safety** and reliability and. Advanced software control algorithms and multiple temperature sensors ensure **accurate and safe** blood and fluid warming.

“Prime, insert the set, switch on and the Fluido® Compact is ready to use”



### Fluido® Compact System | Article number 650000

Consisting of the Control Module, Warming Module and Holder for Warming Module.

### Fluido® Compact Control Module | Article number 650100

|                              |                         |
|------------------------------|-------------------------|
| Dimensions                   | 285 x 120 x 195mm       |
| Weight                       | < 1700g                 |
| Voltage                      | 100 - 240V~ (50/60Hz)   |
| Max. power                   | 160W                    |
| Classification (IEC 60601-1) | Class II, Body Floating |
| Classification (IEC 60529)   | IPX1                    |

### Fluido® Compact Warming Module | Article number 650200

|                              |                         |
|------------------------------|-------------------------|
| Dimensions                   | 165 x 75 x 50mm         |
| Weight                       | < 450g                  |
| Temperature setpoint         | 39°C                    |
| Classification (IEC 60601-1) | Class II, Body Floating |
| Classification (IEC 60529)   | IPX4                    |

### Fluido® Compact Holder for Warming Module | Article number 660700

|              |                   |
|--------------|-------------------|
| Box quantity | 10 (10 x 1 piece) |
|--------------|-------------------|

To provide maximum flexibility in placing the Warming Module near the patient, keeping in mind the mounting options on the OR.

### Fluido® Compact Standard Set | Article number 672000

|                   |  |
|-------------------|--|
| Priming volume    | 4ml (5ml with 300mmHg pressure)              |
| Patient line      | 400mm  |
| Max. flow         | 400ml/min <sup>9</sup>                       |
| Normothermic flow | 5 - 100ml/min <sup>10</sup> (300 - 6000ml/h) |
| Heat exchanger    | Parylene-coated aluminum plate               |
| Box quantity      | 120 (4 x 30 pieces)                          |

### Fluido® Compact Standard Set with drip chamber | Article number 672100

|                   |   |
|-------------------|---|
| Priming volume    | 15ml (16ml with 300mmHg pressure)             |
| Patient line      | 700mm   |
| Max. flow         | 400ml/min <sup>9</sup>                        |
| Normothermic flow | 15 - 100ml/min <sup>10</sup> (900 - 6000ml/h) |
| Heat exchanger    | Parylene coated aluminum plate                |
| Box quantity      | 60 (4 x 15 pieces)                            |

## The Surgical Company PTM - Specialization through Innovation

Our Patient Temperature Management product portfolio is all about offering solutions for patient warming, about keeping patients at a constant healthy body temperature.

The Surgical Company PTM is working with respected medical professionals to accomplish continuous innovation, improve patient outcome and to reduce health care costs. This by providing training, education and economically justified, best-in-class products.

- 1 Sessler D., Mild perioperative hypothermia. N Engl J Med, June 1997, 336(24):1730-1737
- 2 Evans J.W, Singer M., Coppinger S.W. et al., Cardiovascular performance and core temperature during transurethral prostatectomy. J. Urol 1994, 152:2025-9
- 3 ECRI Report, Warming Units, Blood/Solution, December 2002
- 4 Luna G.K., et al., Incidence and Effect of Hypothermia in Seriously Injured Patients, The Journal of Trauma (1987)
- 5 Jurkovich G.J., Hall G.M., Hypothermia in trauma victims: An ominous predictor of survival. The Journal of Trauma (1987)
- 6 Kurz A., Sessler D., Lenhardt R., Perioperative normothermia to reduce the incidence of surgical-wound infection and shorten hospitalization. Study of Wound Infection and Temperature Group, New England Journal of Medicine (1996) 334: 1209-15
- 7 Incoming fluid temperature of 20°C, flow rate 650ml/min
- 8 Specific flow ranges are mentioned in the specifications of the disposable sets
- 9 Free flow with 300 mmHg
- 10 Incoming fluid temperature of 20°C, normothermic flow between 36°C and 37.5°C

## Virtual37® Temperature Management Tool

Virtual37 is a Temperature Management Tool. This simulation tool offers an innovative and easy way to understand the impact of the warming balance and the warming decisions taken in surgeries.

The tool has been validated by University Hospital Ghent, Belgium.



**Mistral-Air®**  
Forced Air Warming

**Fluido®**  
Blood and Fluid Warming

**Thermoflect®**  
Heat Reflective Technology

**Fluido® Irrigation**  
Fluid Warming

**Broncoflex®**  
Single-use Bronchoscope

**Sensium®**  
Wireless Vitals Monitoring

Fluido® and Mistral-Air® are registered trademarks of The Surgical Company International B.V.  
Fluido® products are covered by the following European patents: 1313521 and 1446179.  
Mistral-Air® Blankets Plus are covered by the following American patent: 12/342,933.  
Other patents pending.  
Thermoflect® is a registered trademark of Encompass Group, LLC.

The Surgical Company PTM  
Beeldschermweg 6F  
NL-3821 AH Amersfoort  
The Netherlands  
Tel.: +31 33 450 72 50  
[tsc-group.com/ptm](http://tsc-group.com/ptm)



Images shown, may differ from the actual product  
© 2022 The Surgical Company Group  
INT/P032-EN/8-7/23